

Profiler® Series 2000 Linear Drive

Slide operation accomplished through 1/8 HP motor working with a threadless stainless steel 1/2" diameter linear drive shaft. A linear travel block describes a helical path along the rotating shaft. Design allows for small header profile with flush installation to 4" jambs.

Maximum slide panel weights :
200 lbs (90.7 kg) - Non-breakout
156 lbs (70.7 kg) - UL listed slide-swing

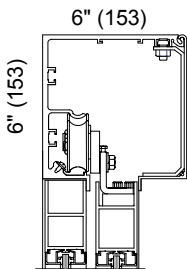
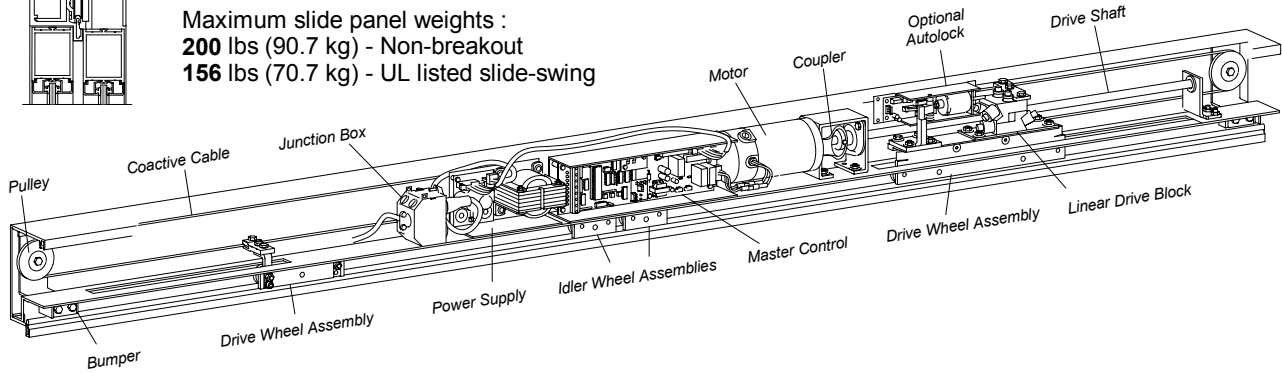

ProSlide® Series 2003 Belt Drive

Slide operation accomplished through 1/8 HP motor working with worm gear transmission and 1800 RPM with 3/4" steel reinforced nylon drive belt, attached door hangers and idler pulley. **Telescoping Series 2003T** included in available door configurations.

Maximum slide panel weights :
250 lbs (90.7 kg) - Non-breakout
156 lbs (70.7 kg) - UL listed slide-swing

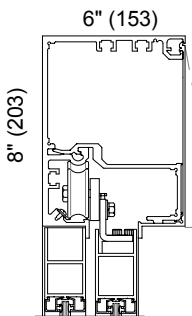
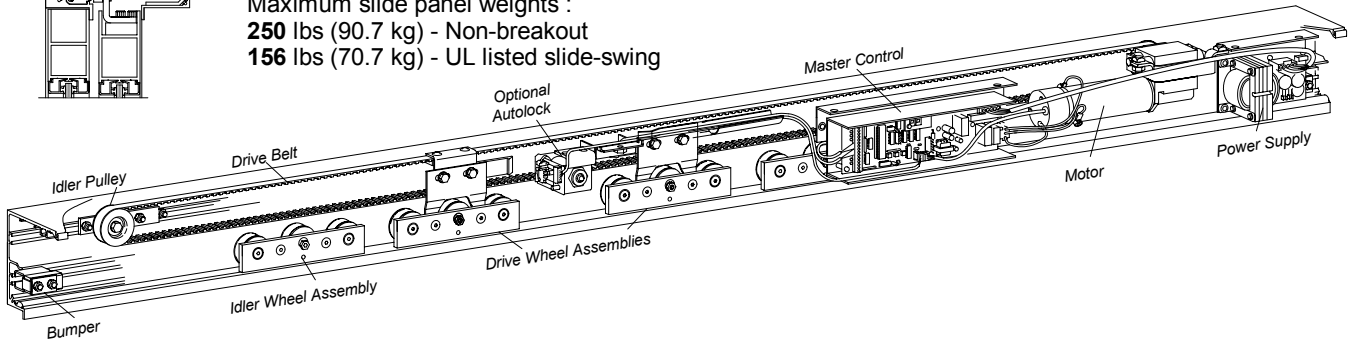

HD-Slide® Series 2001 Belt Drive

Slide operation accomplished through 1/8 HP motor (optional 1/4 HP) working with heavy duty worm gear transmission and 1800 RPM with 1" steel reinforced nylon drive belt, attached 1/4" thick steel door hangers and idler pulley.

Elegant® Series 2500 All-Glass unit included in available door configurations.

Maximum slide panel weights :
500 lbs (227 kg) - Non-breakout singles
300 lbs (136 kg) - Non-breakout bipart
156 lbs (70.7 kg) - UL listed slide-swing

